



# 钎具产品手册

ROCK DRILLING TOOLS PRODUCT CATALOGUE

葫芦岛力天重工机械有限公司



## 公司简介 COMPANY PROFILE

葫芦岛力天重工机械有限公司创建于 2010 年，坐落于辽宁省葫芦岛市，现拥有 18000 平方米生产基地，是一家集凿岩钻具和 TBM 刀具产品研发、生产、销售、服务于一体的高新技术企业。

力天重工专注于生产岩石开挖及矿山采掘使用的破岩工具及钻具。我们与用户密切合作，根据每个用户的施工工况、所使用的设备及开挖方式，设计出最合适的产品及解决方案，帮助用户提高工作效率、降低成本。经过多年的积淀和发展，力天重工产品得到了众多客户的信赖。



## 我们专注于以下多个领域：

### 顶锤钻具

力天重工生产的钻具包括钻杆、钎尾、连接套和钻头，产品应用于露天采矿、地下采矿和隧道开挖等。

### TBM 滚刀

适用于隧道工程的 TBM 和盾构施工。力天重工现已成为国内最大的 TBM 硬岩滚刀生产厂家。

### 反井钻滚刀

适用于各种天井钻机，具有破岩效果好、耐磨性能高、使用寿命长等优点。





公司一角  
COMPANY VIEW



权威认证

AUTHORITATIVE AUTHENTICATION

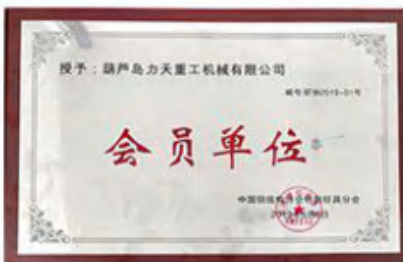





# 应用场景

## APPLICATION

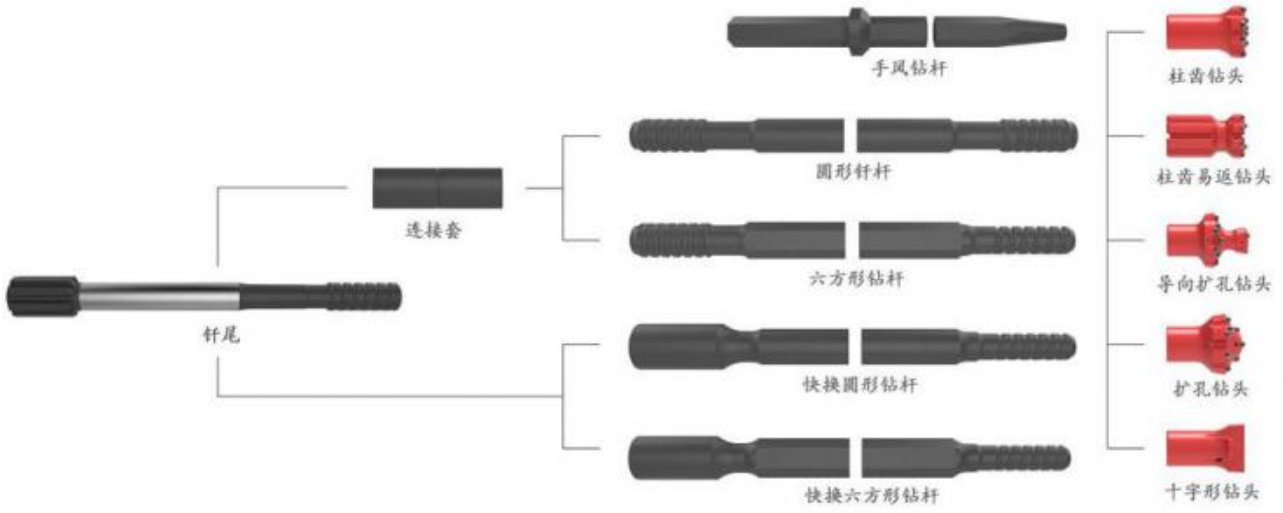

爆破



基础设施建设



矿山



采石场



隧道



## 产品优势

## PRODUCT ADVANTAGE



在 10 多年的实践中,力天重工坚持以客户为中心,努力践行优质服务标准。无论是个体经营者,还是大型跨国施工公司,我们都能够为其提供更好的服务和技术支持。

为此,我们深感自豪!

### ■ 优质钢材

选用高质量钢材和优质硬质合金,经过特殊的热处理工艺,产品不仅达到了掘进使用要求,而且使用寿命更长。

### ■ 先进的制造工艺

采用先进的螺纹制造工艺和独特的表面处理技术,通过精密制造,使产品具有连接紧密、能量传递效果好、耐磨性强及拆卸方便等特点。

### ■ 严格的质量控制

实施严格的质量控制,确保产品的高质量。



# CONTENTS



# 目 录/CONTENTS

产品件号查询指南	1-4
----------	-----

## 钻头

R32	5
T38、T45	6
T51、ST58、ST68	7

## 钻杆

R22、R23、R25	8-9
R28	10
R32	11-13
R35	14
T35	15
T38	16
T45	17-18
T51	18-19
ST58、ST68	19
GT60	20

连接套	21
-----	----

## 钎尾

阿特拉斯•科普柯	22-31
山特维克	32-36
古河	37
蒙特贝	38-40
英格索兰	40-41

## 螺纹钻头

例如：905-102S-3122

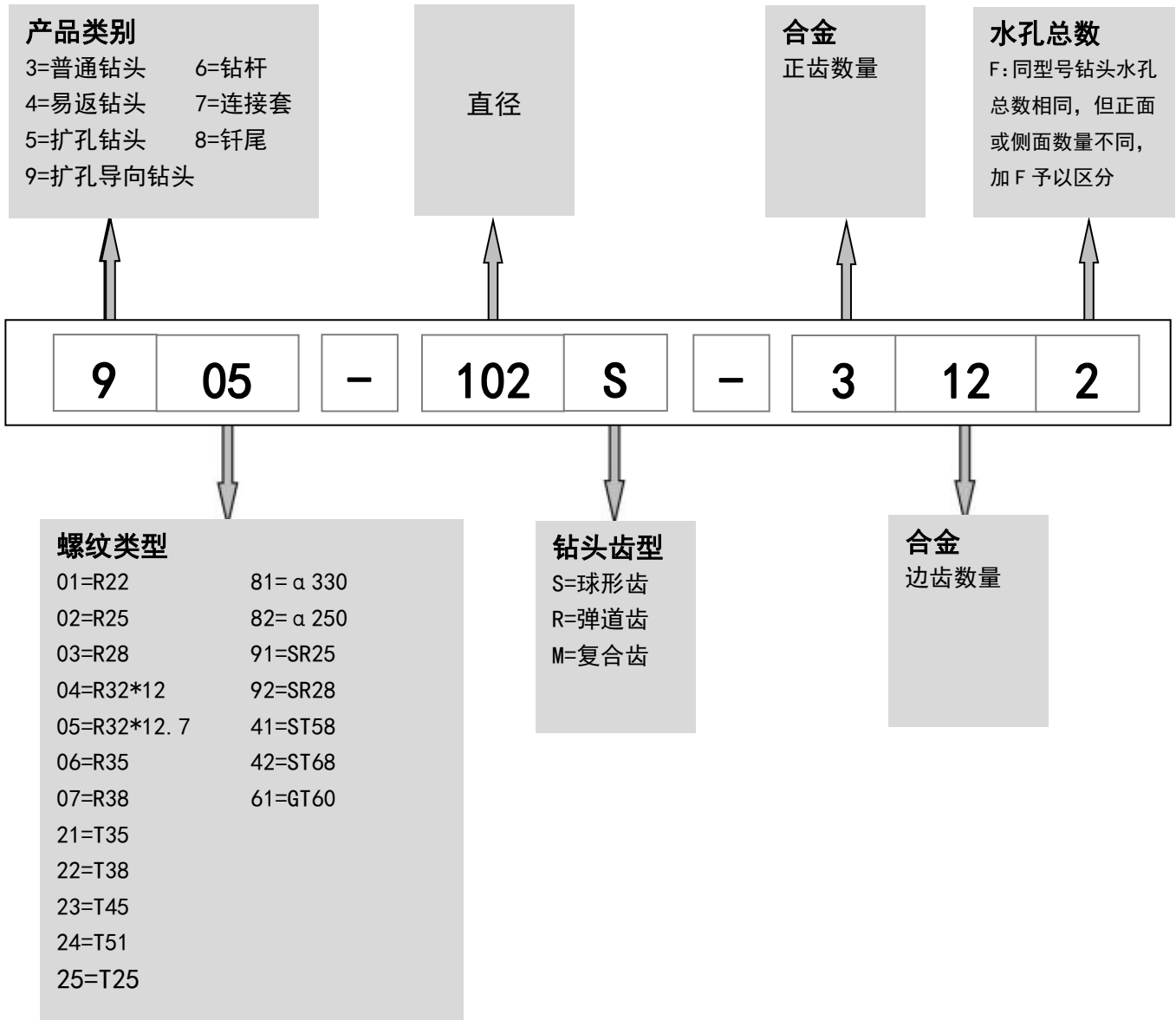

## 螺纹钻杆

例如：605-5137-102

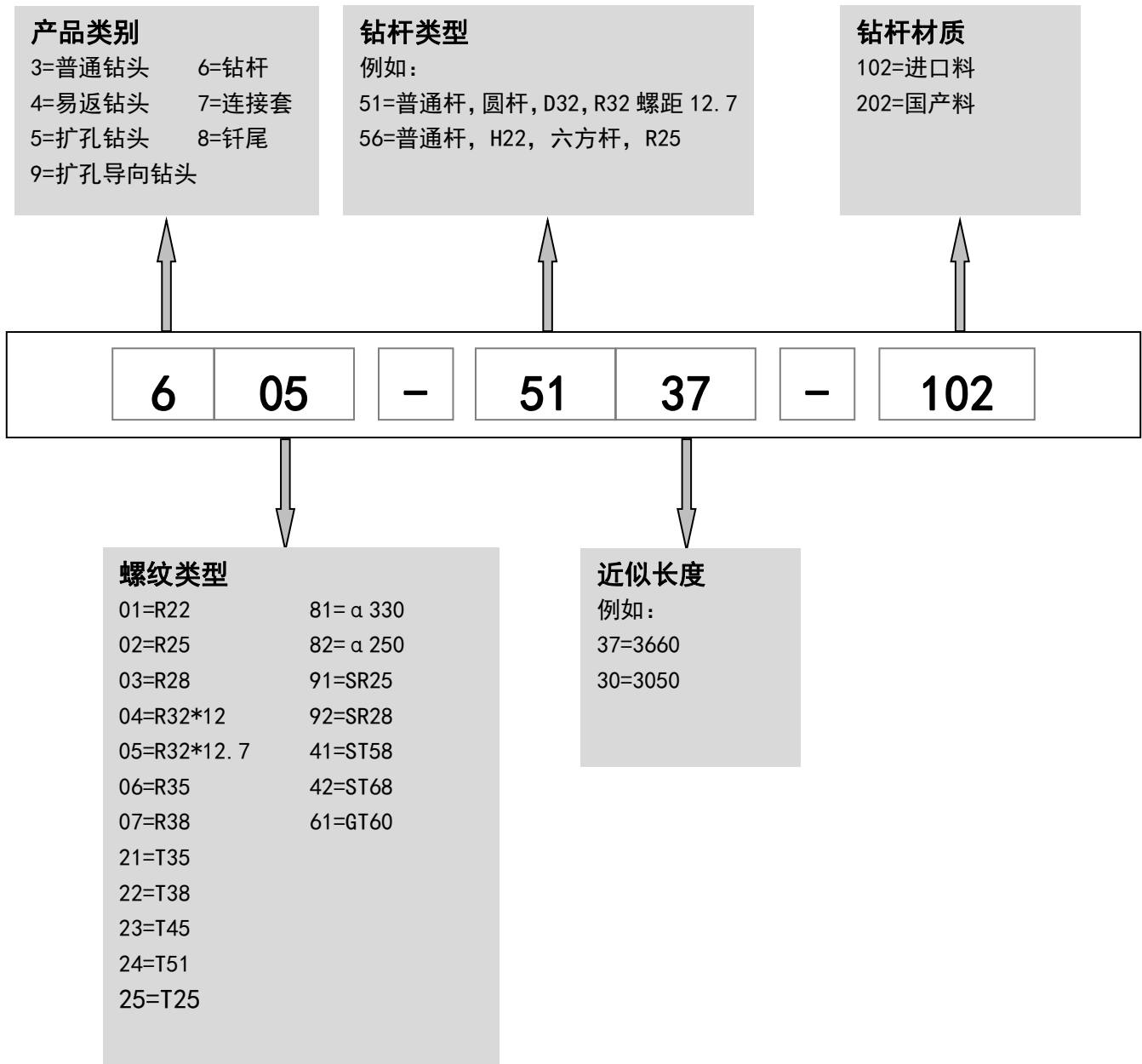



## 钎尾

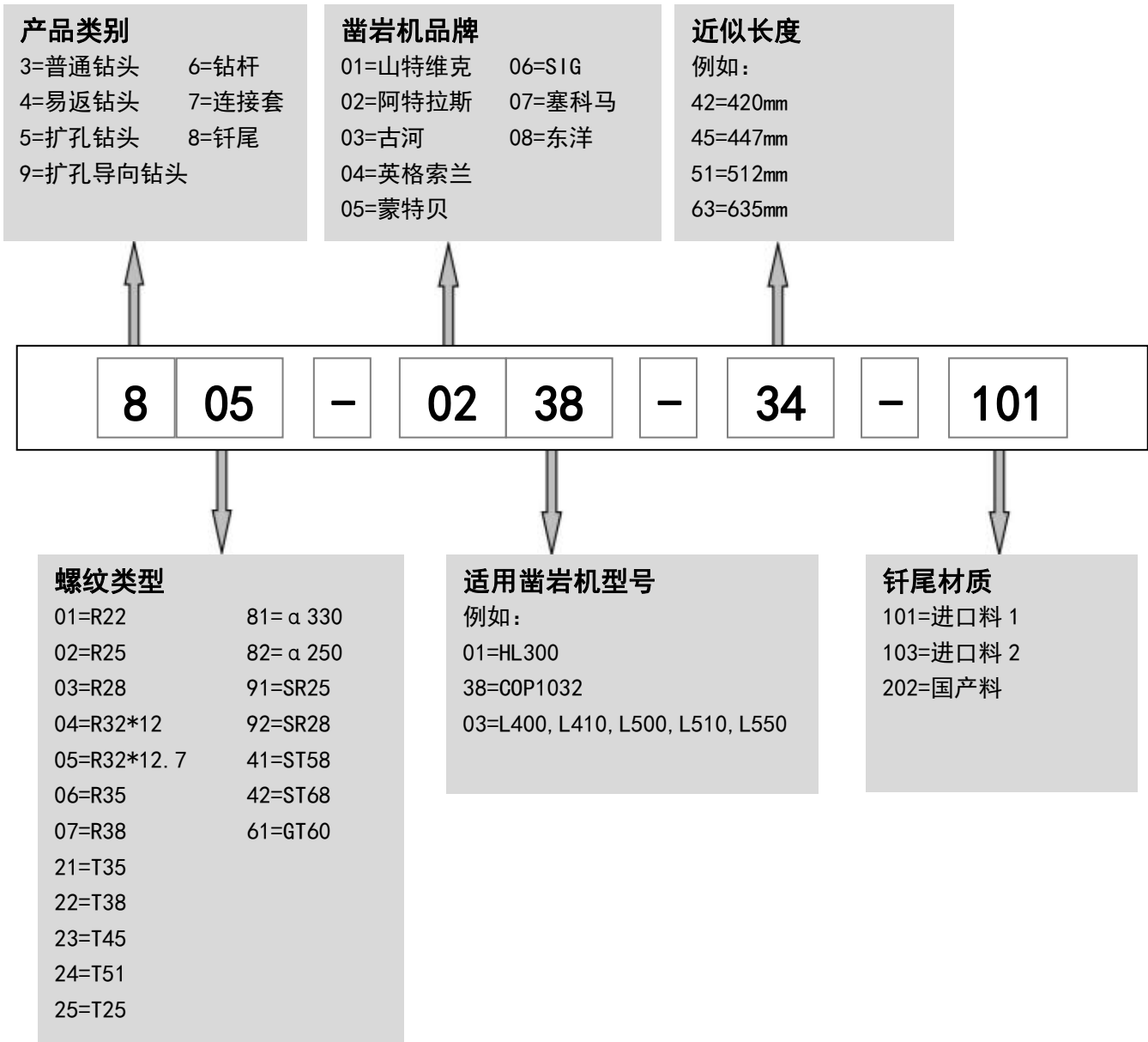

例如：805-0238-34-101





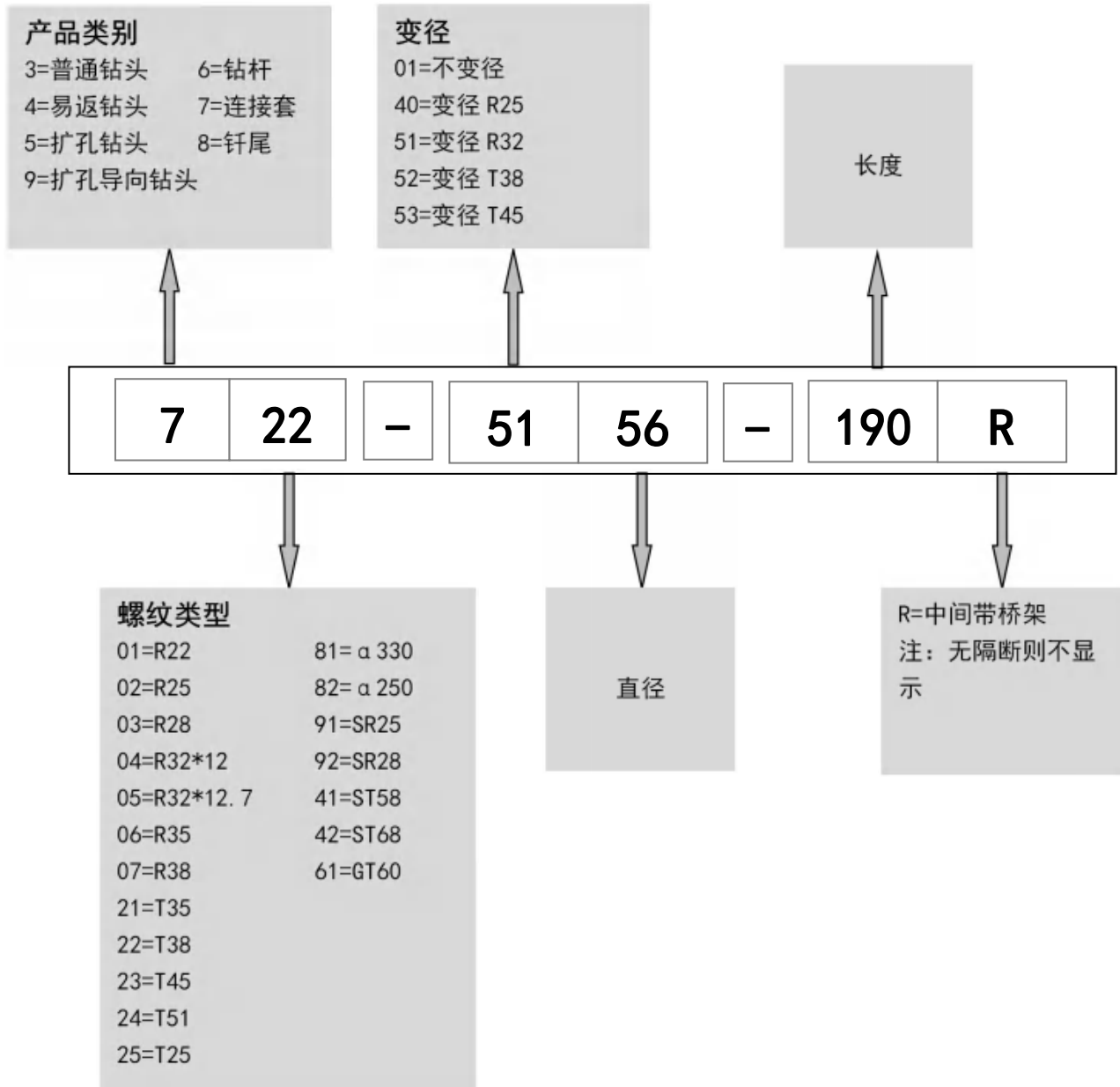



## 连接套







例如：722-5156-190R



钻头	直径		合金数量 X 直径		水孔		约重 (kg)	产品型号	产品件号
	mm	inch	正齿	边齿	正面	侧面			
<b>R32 (1 1/4")</b>									
普通型钻头 	41	1 5/8"	2×8	5×9	1	2	0.5	R32-41S7ZC	305-041S-253
	43	1 11/16"	2×8	5×9	1	1	0.6	R32-43S7ZC R32-43R7ZC	305-043S-252 305-043R-252
	43	1 11/16"	2×8	5×9	2	-	0.6	R32-43R7FZC	305-043R-252F
	45	1 3/4"	2×9	5×10	1	2	0.7	R32-45S7ZC R32-45R7ZC	305-045S-253 305-045R-253
	45	1 3/4"	3×9	6×10	1	1	0.7	R32-45S9ZC R32-45R9ZC	305-045S-362 305-045R-362
	48	1 7/8"	3×9	6×10	3	1	0.9	R32-48S9ZC R32-48R9ZC	305-048S-364 305-048R-364
	48	1 7/8"	2×9	5×10	1	2	0.9	R32-48S7ZC R32-48R7ZC	305-048S-253 305-048R-253
	51	2"	3×9	6×10	3	1	1.2	R32-51S9ZC	305-051S-364
	57	2 1/4"	3×10	6×10	3	1	1.1	R32-57R9ZC	305-057R-364
	64	2 1/2"	4×10	8×10	2	2	1.8	R32-64S12ZC	305-064S-484
	76	3"	4×11	8×11	2	2	2.7	R32-76R12ZC	305-076R-484
扩孔钻头 	89	3 1/2"	3×10	12×12	2	1	2.5	R32-89S15KK	505-089S-3123
扩孔导向钻头 	76	3"	3×10	9×12	1	3	2.0	R32-76S12DX	905-76S-394
	89	3 1/2"	3×10	12×12	1	2	2.7	R32-89S15DX	905-89S-3123
	102	4"	3×10	12×13	4	-	3.2	R32-102S15DX R32-102R15DX	905-102S-3124 905-102R-3124



钻头	直径		合金数量 X 直径		水孔		约重 (kg)	产品型号	产品件号
	mm	inch	正齿	边齿	正面	侧面			
<b>T38 (1 1/2")</b>									
普通型钻头 	64	2 1/2"	4×10	8×10	2	2	1.8	T38-64S12ZC T38-64R12ZC	322-064S-484 322-064R-484
	76	3"	4×11	8×12	2	2	2.6	T38-76S12ZC T38-76R12ZC	322-076S-484 322-076R-484
	89	3 1/2"	6×12	8×12	2	2	3.3	T38-89S14ZC T38-89R14ZC	322-089S-684 322-089R-684
易返型钻头 	64	2 1/2"	4×10	8×10	2	2	2.0	T38-64S12YF T38-64R12YF	422-064S-484 422-064R-484
	76	3"	4×11	8×12	2	-	3.2	T38-76S12YF T38-76R12YF	422-076S-482 422-076R-482
	89	3 1/2"	6×12	8×12	2	-	5.8	T38-89S14YF T38-89R14YF	422-089S-682 422-089R-682
扩孔导向钻头 	127	5"	4×14	8×14	4	-	5.6	T38-127S12DX	922-127S-484
<b>T45 (1 3/4")</b>									
普通型钻头 	76	3"	4×11	8×12	2	2	2.6	T45-76S12ZC T45-76R12ZC	323-076S-484 323-076R-484
	89	3 1/2"	6×12	8×12	2	2	4.5	T45-89S14ZC T45-89R14ZC	323-089S-684 323-089R-684
	102	4"	6×14	8×16	3	-	5.0	T45-102S14ZC T45-102R14ZC	323-102S-683 323-102R-683
易返型钻头 	76	3"	4×11	8×12	4	-	3.1	T45-76S12YF T45-76R12YF	423-076S-484 423-076R-484
	89	3 1/2"	6×12	8×12	2	2	5.3	T45-89S14YF T45-89R14YF	423-089S-684 423-089R-684
	102	4"	6×14	8×16	3	-	8.4	T45-102S14YF T45-102R14YF	423-102S-683 423-102R-683
扩孔导向钻头 	127	5"	4×14	8×14	4	-	6.9	T45-127S12DX	923-127S-484
	152	6"	8×14	8×14	4	-	9.3	T45-152S16DX	923-152S-884

钻头	直径		合金数量 X 直径		水孔		约重 (kg)	产品型号	产品件号
	mm	inch	正齿	边齿	正面	侧面			
<b>T51 (2")</b>									
普通型钻头 	89	3 1/2"	6×12	8×12	2	2	4.9	T51-89S14ZC T51-89R14ZC	324-089S-684 324-089R-684
	102	4"	6×14	8×16	2	-	6.0	T51-102S14ZC T51-102R14ZC	324-102S-682 324-102R-682
易返型钻头 	89	3 1/2"	6×12	8×12	2	-	5.1	T51-89S14YF T51-89R14YF	424-089S-682 424-089R-682
	102	4"	6×14	8×16	3	-	7.5	T51-102S14YF T51-102R14YF	424-102S-683 424-102R-683
扩孔导向钻头 	152	6"	8×14	8×14	1	1	9.3	T51-152S16DX	924-152S-882
<b>ST58 (2 1/4")</b>									
普通型钻头 	89	3 1/2"	5	8	4	-	3.6	ST58-89S13ZC	341-089S-584
	89	3 1/2"	5	8	2	-	3.8	ST58-89S13FZC	341-089S-582
	102	4"	6	8	4	-	5.4	ST58-102R14ZC	341-102R-684
	102	4"	6	8	2	-	5.5	ST58-102R14FZC	341-102R-682
<b>ST68 (2 3/4")</b>									
普通型钻头 	102	4"	6	8	4	-	5.4	ST68-102R14ZC	342-102R-684
	102	4"	6	8	2	-	5.5	ST68-102R14FZC	342-102R-682
	115	4 1/2"	7	8	4	-	6.3	ST68-115S15ZC	342-115S-784
	115	4 1/2"	8	9	3	1	6.5	ST68-115S17ZC	342-115S-894
易返型钻头 	102	4"	6	8	4	-	5.4	ST68-102R14YF	442-102R-684
	115	4 1/2"	6	8	4	-	6.3	ST68-115R14YF	442-115R-684

钻杆	长度		直径		约重 (kg)	产品型号	产品件号
	mm	ft	mm	inch			
<b>R22 (7/8")</b>							
普通钻杆 (六方杆) R22-H22-R22	800	2'	22	7/8"	2.4	R22-H22-800	601-8108-102 601-8108-202
	1200	3'	22	7/8"	3.6	R22-H22-1200	601-8112-102 601-8112-202
	1600	5'	22	7/8"	3.8	R22-H22-1600	601-8116-102 601-8116-202
<b>R23 (29/32")</b>							
快换钻杆 (六方杆) R23-H22-R23	2095	6'	22	7/8"	6.4	MF-R22-H22-2095	601-8221-102 601-8221-202
	3050	10'	22	7/8"	10	MF-R22-H22-3050	601-8230-102 601-8230-202
<b>R25 (1")</b>							
普通钻杆 (六方杆) R25-H25-R25	915	3'	25	1"	3.6	R25-H25-915	602-5709-102 602-5709-202
	1220	4'	25	1"	4.6	R25-H25-1220	602-5712-102 602-5712-202
	1525	5'	25	1"	5.7	R25-H25-1525	602-5715-102 602-5715-202
	1830	6'	25	1"	6.9	R25-H25-1830	602-5718-102 602-5718-202
	2435	8'	25	1"	9	R25-H25-2435	602-5724-102 602-5724-202
	3050	10'	25	1"	12	R25-H25-3050	602-5730-102 602-5730-202



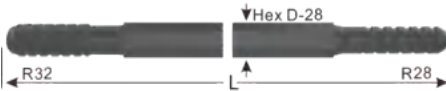

钻杆	长度		直径		约重 (kg)	产品型号	产品件号
	mm	ft	mm	inch			
<b>R25 (1")</b>							
掘进台车钻杆（六方杆） R32-H25-R25  	1870	6'	25	1"	6.9	R32/R25-H25-1870	605-5919-102 605-5919-202
	2175	7'	25	1"	8.4	R32/R25-H25-2175	605-5922-102 605-5922-202
	2475	8'	25	1"	9.5	R32/R25-H25-2475	605-5925-102 605-5925-202
	2630	8'	25	1"	10	R32/R25-H25-2630	605-5926-102 605-5926-202
	2785	9'	25	1"	11	R32/R25-H25-2785	605-5928-102 605-5928-202
	2935	9'	25	1"	16	R32/R25-H25-2935	605-5929-102 605-5929-202
	3090	10'	25	1"	12	R32/R25-H25-3090	605-5931-102 605-5931-202
	3340	10'	25	1"	12	R32/R25-H25-3340	605-5933-102 605-5933-202
	3700	12'	25	1"	14	R32/R25-H25-3700	605-5937-102 605-5937-202
掘进台车钻杆（六方杆） R32-H28-R25  	2630	8'	28	1 1/8"	14	R32/R25-H28-2630	605-8326-102 605-8326-202
	3090	10'	28	1 1/8"	16	R32/R25-H28-3090	605-8331-102 605-8331-202

钻杆	长度		直径		约重 (kg)	产品型号	产品件号
	mm	ft	mm	inch			
<b>R28 (1")</b>							
掘进台车钻杆（六方杆） R32-H28-R28  	2475	8'	28	1 1/8"	12	R32/R28-H28-2475	605-6225-102 605-6225-202
	2785	9'	28	1 1/8"	14	R32/R28-H28-2785	605-6228-102 605-6228-202
	3090	10'	28	1 1/8"	15	R32/R28-H28-3090	605-6231-102 605-6231-202
	3340	10'	28	1 1/8"	16	R32/R28-H28-3340	605-6233-102 605-6233-202
	3700	12'	28	1 1/8"	20	R32/R28-H28-3700	605-6237-102 605-6237-202
	4305	14'	28	1 1/8"	21	R32/R28-H28-4305	605-6243-102 605-6243-202

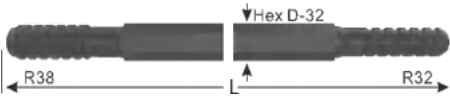
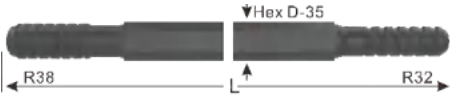
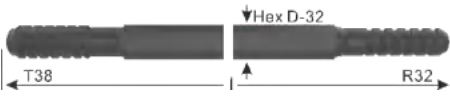
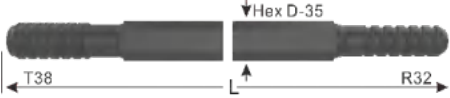
钻杆	长度		直径		约重 (kg)	产品型号	产品件号	
	mm	ft	mm	inch				
<b>R32 (1 1/4")</b>								
普通钻杆 (圆杆) R32-D32-R32	915	3'	32	1 1/4"	5.8	R32-D32-915	605-5109-102 605-5109-202	
	1220	4'	32	1 1/4"	6.3	R32-D32-1220	605-5112-102 605-5112-202	
	1525	5'	32	1 1/4"	8	R32-D32-1525	605-5115-102 605-5115-202	
	1830	6'	32	1 1/4"	9.8	R32-D32-1830	605-5118-102 605-5118-202	
	2435	8'	32	1 1/4"	13	R32-D32-2435	605-5124-102 605-5124-202	
	3050	10'	32	1 1/4"	16	R32-D32-3050	605-5130-102 605-5130-202	
	3660	12'	32	1 1/4"	20	R32-D32-3660	605-5137-102 605-5137-202	
	4265	13'	32	1 1/4"	23	R32-D32-4265	605-5143-102 605-5143-202	
	掘进台车钻杆 (圆杆) T38-D38-R32	5525	18'	38	1 1/2"		T38/R32-D38-5525	622-9855-102 622-9855-202
	掘进台车钻杆 (六方杆) R38-H32-R32	2475	8'	32	1 1/4"	16	R38/R32-H32-2475	607-6625-102 607-6625-202
	3090	10'	32	1 1/4"	20	R38/R32-H32-3090	607-6631-102 607-6631-202	
	3700	12'	32	1 1/4"	24	R38/R32-H32-3700	607-6637-102 607-6637-202	
	4305	14'	32	1 1/4"	27	R38/R32-H32-4305	607-6643-102 607-6643-202	

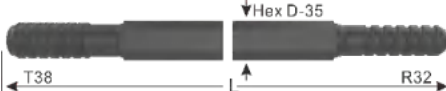
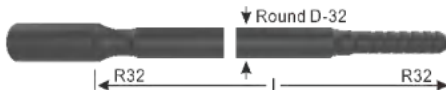
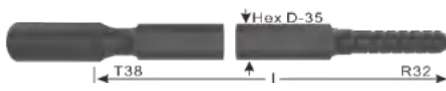
钻杆	长度		直径		约重 (kg)	产品型号	产品件号
	mm	ft	mm	inch			
<b>R32 (1 1/4")</b>							
掘进台车钻杆（六方杆） R38-H32-R32 	4915	16'	32	1 1/4"	31	R38/R32-H32-4915	607-6649-102 607-6649-202
掘进台车钻杆（六方杆） R38-H35-R32 	3090	10'	35	1 3/8"	24	R38/R32-H35-3090	607-8431-102 607-8431-202
	3700	12'	35	1 3/8"	28	R38/R32-H35-3700	607-8437-102 607-8437-202
	4305	14'	35	1 3/8"	34	R38/R32-H35-4305	607-8443-102 607-8443-202
	4915	16'	35	1 3/8"	37	R38/R32-H35-4915	607-8449-102 607-8449-202
	5525	18'	35	1 3/8"	42	R38/R32-H35-5525	607-8455-102 607-8455-202
掘进台车钻杆（六方杆） T38-H32-R32 	3090	10'	32	1 1/4"	24	T38/R32-H32-3090	622-6531-102 622-6531-202
	3700	12'	32	1 1/4"	26	T38/R32-H32-3700	622-6537-102 622-6537-202
	4305	14'	32	1 1/4"	28	T38/R32-H32-4305	622-6543-102 622-6543-202
掘进台车钻杆（六方杆） T38-H35-R32 	2475	8'	35	1 3/8"	19	T38/R32-H35-2475	622-8525-102 622-8525-202
	3090	10'	35	1 3/8"	24	T38/R32-H35-3090	622-8531-102 622-8531-202
	3700	12'	35	1 3/8"	28	T38/R32-H35-3700	622-8537-102 622-8537-202
	4305	14'	35	1 3/8"	32	T38/R32-H35-4305	622-8543-102 622-8543-202
	4915	16'	35	1 3/8"	37	T38/R32-H35-4915	622-8549-102 622-8549-202

钻杆	长度		直径		约重 (kg)	产品型号	产品件号
	mm	ft	mm	inch			
<b>R32 (1 1/4")</b>							
掘进台车钻杆（六方杆） T38-H35-R32 	5525	18'	35	1 3/8"	42	T38/R32-H35-5525	622-8555-102 622-8555-202
	6135	20'	35	1 3/8"	44	T38/R32-H35-6135	622-8561-102 622-8561-202
	6440	21'	35	1 3/8"	46	T38/R32-H35-6440	622-8564-102 622-8564-202
快换钻杆（圆杆） R32-D32-R32 	915	3'	32	1 1/4"	5.5	MF-R32-D32-915	605-6909-102 605-6909-202
	1220	4'	32	1 1/4"	7.5	MF-R32-D32-1220	605-6912-102 605-6912-202
	1525	5'	32	1 1/4"	9.1	MF-R32-D32-1525	605-6915-102 605-6915-202
	1830	6'	32	1 1/4"	11	MF-R32-D32-1830	605-6918-102 605-6918-202
	3050	10'	32	1 1/4"	18	MF-R32-D32-3050	605-6930-102 605-6930-202
	3660	12'	32	1 1/4"	21	MF-R32-D32-3660	605-6937-102 605-6937-202
快换钻杆（六方杆） T38-H35-R32 	3700	12'	35	1 3/8"	29	MF-T38/R32-H35-3700	622-7237-102 622-7237-202
	4305	14'	35	1 3/8"	34	MF-T38/R32-H35-4305	622-7243-102 622-7243-202
导向钻杆 R32-D46-R32 	1830	6'	46	1 3/4"	16	R32-D46-1830	605-9618-102 605-9618-202



钻杆	长度		直径		约重 (kg)	产品型号	产品件号
	mm	ft	mm	inch			
<b>R35 (1 3/8")</b>							
掘进台车钻杆（六方杆） T38-D39-R35 	4305	14'	39	1 1/2"	35	T38/R35-D39-4305	622-5243-102 622-5243-202
	4915	16'	39	1 1/2"	40	T38/R35-D39-4915	622-5249-102 622-5249-202
	5525	18'	39	1 1/2"	45	T38/R35-D39-5525	622-5255-102 622-5255-202
	6135	20'	39	1 1/2"	49	T38/R35-D39-6135	622-5261-102 622-5261-202
掘进台车钻杆（六方杆） T38-H35-R35 	4305	14'	35	1 3/8"	34	T38/R35-H35-4305	622-8643-102 622-8643-202
	4915	16'	35	1 3/8"	37	T38/R35-H35-4915	622-8649-102 622-8649-202
	5525	18'	35	1 3/8"	42	T38/R35-H35-5525	622-8655-102 622-8655-202
	6135	20'	35	1 3/8"	46	T38/R35-H35-6135	622-8661-102 622-8661-202
快换钻杆（圆杆） T35-D39-R35 	4305	14'	39	1 1/2"	35	MF-T35/R35-D39-4305	621-7543-102 621-7543-202
	4915	16'	39	1 1/2"	40	MF-T35/R35-D39-4915	621-7549-102 621-7549-202
	5525	18'	39	1 1/2"	45	MF-T35/R35-D39-5525	621-7555-102 621-7555-202
	6135	20'	39	1 1/2"	50	MF-T35/R35-D39-6135	621-7561-102 621-7561-202

钻杆	长度		直径		约重 (kg)	产品型号	产品件号
	mm	ft	mm	inch			
<b>T35 (1 3/8")</b>							
快换钻杆 (圆杆) T35-D39-T35  	1830	6'	39	1 1/2"	16	MF-T35-D39-1830	621-8718-102 621-8718-202
	3050	10'	39	1 1/2"	25	MF-T35-D39-3050	621-8730-102 621-8730-202
	3660	12'	39	1 1/2"	32	MF-T35-D39-3660	621-8737-102 621-8737-202
	4265	14'	39	1 1/2"	35	MF-T35-D39-4265	621-8743-102 621-8743-202
	4875	16'	39	1 1/2"	40	MF-T35-D39-4875	621-8749-102 621-8749-202

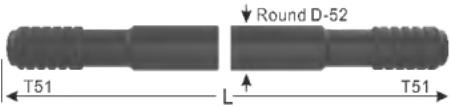

钻杆	长度		直径		约重 (kg)	产品型号	产品件号	
	mm	ft	mm	inch				
<b>T38 (1 1/2")</b>								
普通钻杆 (圆杆) T38-D39-T38		3050	10'	39	1 1/2"	24	T38-D39-3050	622-8930-102 622-8930-202
		3660	12'	39	1 1/2"	29	T38-D39-3660	622-8937-102 622-8937-202
普通钻杆 (六方杆) T38-H32-T38		3050	10'	32	1 1/4"	18	T38-H32-3050	622-9130-102 622-9130-202
快换钻杆 (圆杆) T38-D39-T38		915	3'	39	1 1/2"	8.1	MF-T38-D39-915	622-7709-102 622-7709-202
		1220	4'	39	1 1/2"	11	MF-T38-D39-1220	622-7712-102 622-7712-202
		1525	5'	39	1 1/2"	12	MF-T38-D39-1525	622-7715-102 622-7715-202
		1830	6'	39	1 1/2"	15	MF-T38-D39-1830	622-7718-102 622-7718-202
		3050	10'	39	1 1/2"	25	MF-T38-D39-3050	622-7730-102 622-7730-202
		3660	12'	39	1 1/2"	30	MF-T38-D39-3660	622-7737-102 622-7737-202
		4265	14'	39	1 1/2"	36	MF-T38-D39-4265	622-7743-102 622-7743-202
		4875	16'	39	1 1/2"	41	MF-T38-D39-4875	622-7749-102 622-7749-202
导向钻杆 T38-D56-T38		1830	6'	56	2 13/64"	24	T38-D56-1830	622-9018-102 622-9018-202
		3660	12'	56	2 13/64"	48	T38-D56-3660	622-9037-102 622-9037-202

钻杆	长度		直径		约重 (kg)	产品型号	产品件号
	mm	ft	mm	inch			
<b>T45 (1 3/4")</b>							
普通钻杆 (圆杆) T45-D46-T45		3050	10'	46	1 3/4"	33	T45-D46-3050 623-5430-102 623-5430-202
		3660	12'	46	1 3/4"	40	T45-D46-3660 623-5437-102 623-5437-202
		4265	14'	46	1 3/4"	47	T45-D46-4265 623-5443-102 623-5443-202
快换钻杆 (圆杆) T45-D46-T45		1220	4'	46	1 3/4"	14	MF-T45-D46-1220 623-7912-102 623-7912-202
		1525	5'	46	1 3/4"	18	MF-T45-D46-1525 623-7915-102 623-7915-202
		1830	6'	46	1 3/4"	21	MF-T45-D46-1830 623-7918-102 623-7918-202
		3050	10'	46	1 3/4"	35	MF-T45-D46-3050 623-7930-102 623-7930-202
		3660	12'	46	1 3/4"	41	MF-T45-D46-3660 623-7937-102 623-7937-202
		4265	14'	46	1 3/4"	48	MF-T45-D46-4265 623-7943-102 623-7943-202
		6095	14'	46	1 3/4"	48	MF-T45-D46-6095 623-7961-102 623-7961-202
导向钻杆 T45-D63-T45		1830	6'	63	2 31/64"	24	T45-D63-1830 623-9218-102 623-9218-202
		3660	12'	63	2 31/64"	46	T45-D63-3660 623-9237-102 623-9237-202
导向钻杆 T45-D76-T45		3660	12'	76	3"	78	T45-D76-3660 623-9337-102 623-9337-202

钻杆	长度		直径		约重 (kg)	产品型号	产品件号
	mm	ft	mm	inch			
<b>T51 (2")</b>							
普通钻杆 (圆杆) T51-D52-T51	3660	12'	52	2"	50	T51-D52-3660	624-5537-102 624-5537-202
	4265	14'	52	2"	56	T51-D52-4265	624-5543-102 624-5543-202
	6095	20'	52	2"	85	T51-D52-6095	624-5561-102 624-5561-202
快换钻杆 (圆杆) T51-D52-T51	1525	5'	52	2"	23	MF-T51-D52-1525	624-8015-102 624-8015-202
	1830	6'	52	2"	27	MF-T51-D52-1830	624-8018-102 624-8018-202
	3660	12'	52	2"	50	MF-T51-D52-3660	624-8037-102 624-8037-202
	4265	14'	52	2"	57	MF-T51-D52-4265	624-8043-102 624-8043-202
	5485	17'	52	2"	72	MF-T51-D52-5485	624-8055-102 624-8055-202
	6095	20'	52	2"	87	MF-T51-D52-6095	624-8061-102 624-8061-202
导向钻杆 T51-D76-T51	1830	6'	76	3"	40	T51-D76-1830	624-9418-102 624-9418-202
	3660	12'	76	3"	76	T51-D76-3660	624-9437-102 624-9437-202
导向钻杆 T51-D87-T51	3660	12'	87	3 1/2"	89	T51-D87-3660	624-9537-102 624-9537-202
							



钻杆	长度		直径		约重 (kg)	产品型号	产品件号
	mm	ft	mm	inch			
<b>ST58 (2 1/4")</b>							
钻管 ST58-DN76-ST58 	1525	5'	76	3"	33	ST58-DN76-1525	641-10315-102 641-10315-202
	1830	6'	76	3"	41	ST58-DN76-1830	641-10318-102 641-10318-202
<b>ST68 (2 3/4")</b>							
钻管 ST68-DN87-ST68 	1525	5'	87	3 1/2"	40	ST68-DN87-1525	642-10415-102 642-10415-202
	1830	6'	87	3 1/2"	48	ST68-DN87-1830	642-10418-102 642-10418-202

钻杆	长度		直径		约重 (kg)	产品型号	产品件号
	mm	ft	mm	inch			
<b>GT60 (2 3/8")</b>							
快换钻杆 (圆杆) GT60-D60-GT60	3660	12'	60	2 3/8"	73	MF-GT60-D60-3660	661-10037-102 661-10037-202
	4265	14'	60	2 3/8"	86	MF-GT60-D60-4265	661-10043-102 661-10043-202
	5485	18'	60	2 3/8"	107	MF-GT60-D60-5485	661-10055-102 661-10055-202
	6095	20'	60	2 3/8"	120	MF-GT60-D60-6095	661-10061-102 661-10061-202
<b>GT60 (2 3/8")</b>							
快换钻杆 (圆杆) GT60-D64-GT60	4265	14'	64	2 1/2"	92	MF-GT60-D64-4265	661-10143-102 661-10143-202
							
钻管 GT60-DN87-GT60	4265	14'	87	3 1/2"	104	GT60-DN87-4265	661-10243-102 661-10243-202
							

连接套	两端螺纹	长度		直径		约重 (kg)	产品型号	件号
		mm	inch	mm	inch			
	R32	160	6 1/4"	45	1 3/4"	1.0	LR32-D45-160	705-0145-160
	R38	180	7 1/8"	56	2 13/64"	2.0	LR38-D56-180	707-0156-180
	T38	190	7 1/2"	56	2 13/64"	1.9	LT38-D56-190	722-0156-190
	T45	210	8 1/8"	63	2 31/64"	2.7	LT45-D63-210	723-0163-210
	T51	235	9 1/4"	71	2 51/64"	3.8	LT51-D71-235	724-0171-235
	R38-R32	180	7 1/8"	56	2 13/64"	2.1	LR38/R32-D56-180	707-5156-180
		190	7 1/2"	56	2 13/64"	2.2	LR38/R32-D56-190R	707-5156-190R
	T38-R32	180	7 1/8"	56	2 13/64"	2.1	LT38/R32-D56-180	722-5156-180
		190	7 1/2"	56	2 13/64"	2.2	LT38/R32-D56-190R	722-5156-190R
	T38/R38	180	7 1/8"	56	2 13/64"	2.4	LT38/R38-56-180	722-0756-180
		190	7 1/2"	56	2 13/64"	2.5	LT38/R38-56-190	722-0756-190
	T51-T45	225	8 7/8"	71	2 51/64"	4.5	LT51/T45-D71-225	724-5371-225

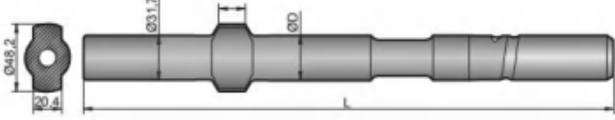
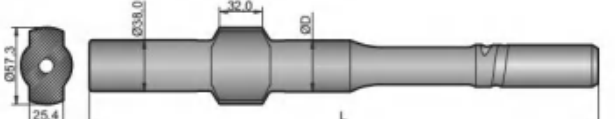
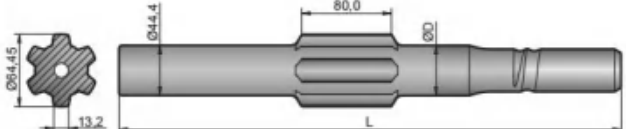
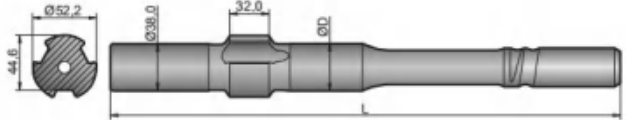
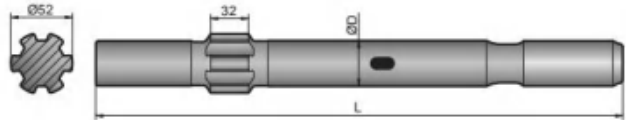
钎尾	螺纹	长度	直径	约重	产品型号	产品件号
		mm	mm	kg		
<b>ATLAS COPCO BBC 43, BBC 44, BBC 45, BBC 100</b>						
	R32	380	32	2.1	R32*2D32-380	805-0233-38-101 805-0233-38-103 805-0233-38-202
<b>ATLAS COPCO BBC 51, BBC 52, BBC 54, BBC 120</b>						
	R32	380	38	2.6	R32*2D38-380	805-0234-38-101 805-0234-38-103 805-0234-38-202
	R38	390	38	3.1	R38*2D38-390	807-0234-39-101 807-0234-39-103 807-0234-39-202
	T38	390	38	3.1	T38*2D38-390	822-0234-39-101 822-0234-39-103 822-0234-39-202
<b>ATLAS COPCO BBE 57</b>						
	R38	447	45	5.0	R38*6D45-447	807-0235-45-101 807-0235-45-103 807-0235-45-202
	T38	540	45	5.3	T38*6D45-540	822-0235-54-101 822-0235-54-103 822-0235-54-202
<b>ATLAS COPCO COP 125, COP 130, COP 131</b>						
	T38	380	38	3	T38*3D38-380	822-0236-38-101 822-0236-38-103 822-0236-38-202
	T45	380	38	3	T45*3D38-380	823-0236-38-101 823-0236-38-103 823-0236-38-202
<b>ATLAS COPCO COP 131</b>						
	T38	445	38	3.8	T38*6D38-445	822-0290-44-101 822-0290-44-103 822-0290-44-202

钎尾	螺纹	长度	直径	约重	产品型号	产品件号
		mm	mm	kg		
<b>ATLAS COPCO COP 131E</b>						
	T38	380	38	2.8	T38*6D38-380	822-0291-38-101 822-0291-38-103 822-0291-38-202
<b>ATLAS COPCO COP 131EB</b>						
	T38	405	38	3.2	T38*6D38-405	822-0292-40-101 822-0292-40-103 822-0292-40-202
<b>ATLAS COPCO COP 1028</b>						
	R28	400	45	2.6	R28*5D45-400	803-0293-40-101 803-0293-40-103 803-0293-40-202
	R32	400	45	2.8	R32*5D45-400	805-0293-40-101 805-0293-40-103 805-0293-40-202
<b>ATLAS COPCO COP 1032</b>						
	R32	340	45	3.4	R32*8D45-340	805-0238-34-101 805-0238-34-103 805-0238-34-202
	R38	340	55	4.1	R38*8D55-340	807-0238-34-101 807-0238-34-103 807-0238-34-202
	R32	550	45	5.0	R32*8D45-550	805-0238-55-101 805-0238-55-103 805-0238-55-202
	T38	550	45	5.4	T38*8D45-550	822-0238-55-101 822-0238-55-103 822-0238-55-202
	R32	510	45	4.9	R32*8D45-510	805-0238-51-101 805-0238-51-103 805-0238-51-202

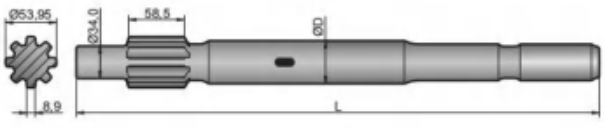
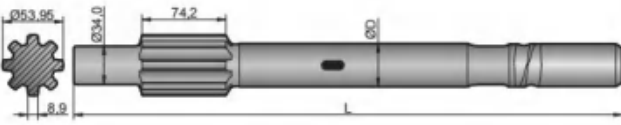
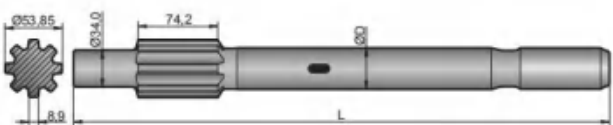
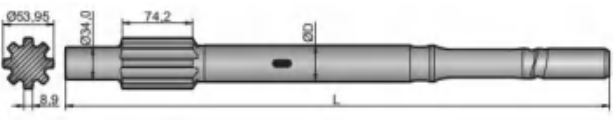

钎尾	螺纹	长度	直径	约重	产品型号	产品件号
		mm	mm	kg		
<b>ATLAS COPCO COP 1032</b>						
	T38	510	45	5.0	T38*8D45-510	822-0238-51-101 822-0238-51-103 822-0238-51-202
<b>ATLAS COPCO COP 1238</b>						
	T38	485	38	4.1	T38*8D38-485	822-0244-48-101 822-0244-48-103 822-0244-48-202
	R38	485	38	4.1	R38*8D38-485	807-0244-48-101 807-0244-48-103 807-0244-48-202
	T38	500	38	4.8	T38*8D38-500	822-0244-50-101 822-0244-50-103 822-0244-50-202
	T45	500	45	5.1	T45*8D45-500	823-0244-50-101 823-0244-50-103 823-0244-50-202
	R32	575	38	4.6	R32*8D38-575	805-0244-57-101 805-0244-57-103 805-0244-57-202
	T38	575	38	4.7	T38*8D38-575	822-0244-57-101 822-0244-57-103 822-0244-57-202
	T38	575	45	5.4	T38*8D45-575	822-0244A-57-101 822-0244A-57-103 822-0244A-57-202
	T45	575	45	5.8	T45*8D45-575	823-0244-57-101 823-0244-57-103 823-0244-57-202

钎尾	螺纹	长度	直径	约重	产品型号	产品件号
		mm	mm	kg		
<b>ATLAS COPCO COP 1132</b>						
	R32	410	35	2.5	R32*8D35-410	805-0247-41-101 805-0247-41-103 805-0247-41-202
	R32	500	35	3.0	R32*8D35-500	805-0247-50-101 805-0247-50-103 805-0247-50-202
<b>ATLAS COPCO COP 1140</b>						
	R32	410	35	2.6	R32*8D35-410	805-0295-41-101 805-0295-41-103 805-0295-41-202
<b>ATLAS COPCO COP 1240</b>						
	R32	565	52	6.4	R32*8D52-565	805-0296-56-101 805-0296-56-103 805-0296-56-202
	T38	565	52	6.6	T38*8D52-565	822-0296-56-101 822-0296-56-103 822-0296-56-202
<b>ATLAS COPCO COP 1240EX</b>						
	T38	770	60	10.7	T38*8D60-770	822-0297-77-101 822-0297-77-103 822-0297-77-202
<b>ATLAS COPCO COP 1338EX</b>						
	R32	780	60	10.1	R32*8D60-780	805-0298-78-101 805-0298-78-103 805-0298-78-202

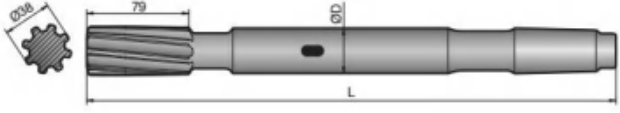
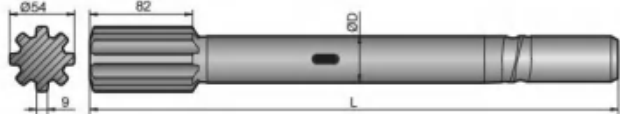
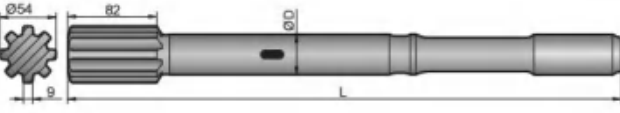
钎尾	螺纹	长度	直径	约重	产品型号	产品件号
		mm	mm	kg		
<b>ATLAS COPCO COP 1435</b>						
	R32	410	35	2.6	R32*8D35-410	805-0299-41-101 805-0299-41-103 805-0299-41-202
	R32	500	35	3.0	R32*8D35-500	805-0299-50-101 805-0299-50-103 805-0299-50-202
<b>ATLAS COPCO COP 1432, COP 1532, COP 1440, COP 1838 HD/ME</b>						
	R38	435	38	3.9	R38*8D38-435	807-0245-43-101 807-0245-43-103 807-0245-43-202
	R32	435	38	3.6	R32*8D38-435	805-0245-43-101 805-0245-43-103 805-0245-43-202
	T38	435	38	3.8	T38*8D38-435	822-0245-43-101 822-0245-43-103 822-0245-43-202
	T35	435	38	3.7	T35*8D38-435	821-0245-43-101 821-0245-43-103 821-0245-43-202
	R32	525	38	4.3	R32*8D38-525	805-0245-52-101 805-0245-52-103 805-0245-52-202
	T35	525	38	4.2	T35*8D38-525	821-0245-52-101 821-0245-52-103 821-0245-52-202
	T38	525	38	4.3	T38*8D38-525	822-0245-52-101 822-0245-52-103 822-0245-52-202

钎尾	螺纹	长度	直径	约重	产品型号	产品件号
		mm	mm	kg		
<b>ATLAS COPCO COP 1550, COP 1838 ME/ HE</b>						
	T38	525	52	6.2	T38*8D52-525	822-0248-52-101 822-0248-52-103 822-0248-52-202
	T45	525	52	6.5	T45*8D52-525	823-0248-52-101 823-0248-52-103 823-0248-52-202
	T51	525	52	6.8	T51*8D52-525	824-0248-52-101 824-0248-52-103 824-0248-52-202
<b>ATLAS COPCO COP 1640</b>						
	T38	565	52	6.6	T38*8D52-565	822-02102-56-101 822-02102-56-103 822-02102-56-202
<b>ATLAS COPCO COP 1640EX</b>						
	T38	770	60	10.7	T38*8D60-770	822-02103-77-101 822-02103-77-103 822-02103-77-202
<b>ATLAS COPCO COP 1838MUX/HUX</b>						
	T38	730	52	9.9	T38*8D52-730	822-02104-73-101 822-02104-73-103 822-02104-73-202
	T45	730	52	9.9	T45*8D52-730	823-02104-73-101 823-02104-73-103 823-02104-73-202

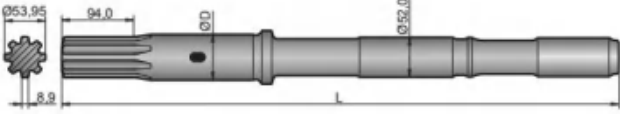
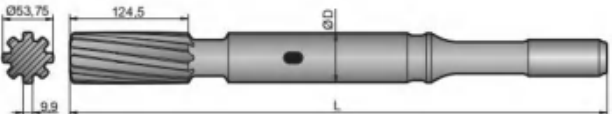
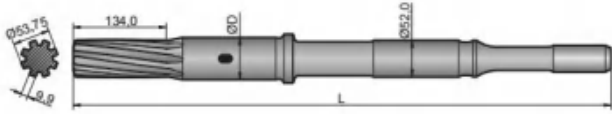
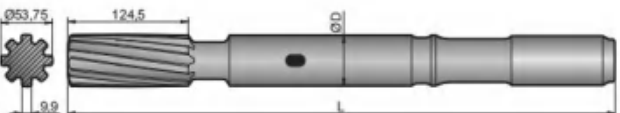
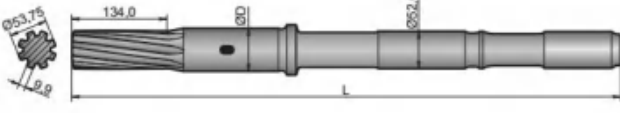
钎尾	螺纹	长度	直径	约重	产品型号	产品件号
		mm	mm	kg		
<b>ATLAS COPCO COP 1838EX</b>						
	T38	730	60	9.8	T38*8D60-730	822-02105-73-101 822-02105-73-103 822-02105-73-202
	T45	730	60	10.2	T45*8D60-730	823-02105-73-101 823-02105-73-103 823-02105-73-202
	T51	730	60	10.4	T51*8D60-730	824-02105-73-101 824-02105-73-103 824-02105-73-202
<b>ATLAS COPCO COP 1840</b>						
	T45	565	52	6.8	T45*8D52-565	823-02106-56-101 823-02106-56-103 823-02106-56-202
	T51	565	52	7.2	T51*8D52-565	824-02106-56-101 824-02106-56-103 824-02106-56-202
<b>ATLAS COPCO COP 1840EX</b>						
	T45	770	60	10.8	T45*8D60-770	823-02107-77-101 823-02107-77-103 823-02107-77-202
	T51	770	60	10.9	T51*8D60-770	824-02107-77-101 824-02107-77-103 824-02107-77-202
<b>ATLAS COPCO COP 1850</b>						
	T51	565	52	7.2	T51*8D52-565	824-02108-56-101 824-02108-56-103 824-02108-56-202
<b>ATLAS COPCO COP 1850EX</b>						
	T51	770	60	10.9	T51*8D60-770	824-02109-77-101 824-02109-77-103 824-02109-77-202

钎尾	螺纹	长度	直径	约重	产品型号	产品件号
		mm	mm	kg		
<b>ATLAS COPCO COP 2150</b>						
	T45	770	52	8.5	T45*8D52-770	823-02110-77-101 823-02110-77-103 823-02110-77-202
	T51	770	52	9.2	T51*8D52-770	824-02110-77-101 824-02110-77-103 824-02110-77-202
<b>ATLAS COPCO COP 2150EX</b>						
	T45	770	60	10.8	T45*8D60-770	823-02111-77-101 823-02111-77-103 823-02111-77-202
	T51	770	60	10.9	T51*8D60-770	824-02111-77-101 824-02111-77-103 824-02111-77-202
<b>ATLAS COPCO COP 2150, COP 2550</b>						
	T51	770	52	9.9	T51*8D52-770	824-0251-77-101 824-0251-77-103 824-0251-77-202
<b>ATLAS COPCO COP 2150EX, COP 2550EX</b>						
	T51	770	60	11.0	T51*8D60-770	824-02112-77-101 824-02112-77-103 824-02112-77-202
<b>ATLAS COPCO COP 2550</b>						
	T51	770	52	9.2	T51*8D52-770	824-02113-77-101 824-02113-77-103 824-02113-77-202

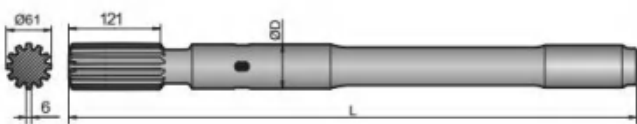
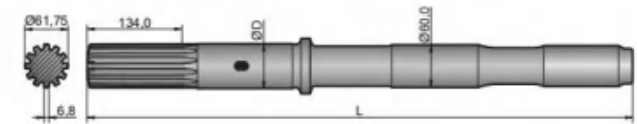
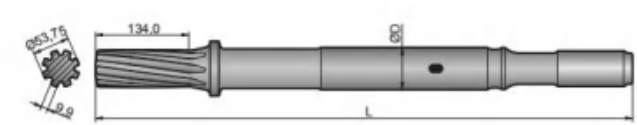
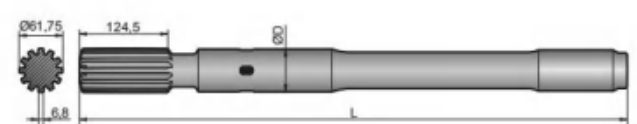
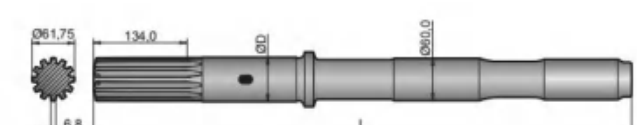

钎尾	螺纹	长度	直径	约重	产品型号	产品件号
		mm	mm	kg		
<b>ATLAS COPCO COP 2160, COP 2560</b>						
	T45	770	60	10.9	T45*12D60-770	823-0252-77-101 823-0252-77-103 823-0252-77-202
	T51	770	60	11.0	T51*12D60-770	824-0252-77-101 824-0252-77-103 824-0252-77-202
<b>ATLAS COPCO COP 2160EX</b>						
	T45	770	63	13.2	T45*12D63-770	823-02115-77-101 823-02115-77-103 823-02115-77-202
	T51	770	63	13.3	T51*12D63-770	824-02115-77-101 824-02115-77-103 824-02115-77-202
<b>ATLAS COPCO COP 2550UX</b>						
	T45	770	60	12.9	T45*8D60-770	823-02116-77-101 823-02116-77-103 823-02116-77-202
	T51	770	60	13.1	T51*8D60-770	824-02116-77-101 824-02116-77-103 824-02116-77-202
<b>ATLAS COPCO COP 2560</b>						
	T51	770	60	11	T51*12D60-770	824-02117-77-101 824-02117-77-103 824-02117-77-202
<b>ATLAS COPCO COP 2560EX</b>						
	T51	770	63	13.3	T51*12D63-770	824-02118-77-101 824-02118-77-103 824-02118-77-202

钎尾	螺纹	长度	直径	约重	产品型号	产品件号
		mm	mm	kg		
<b>ATLAS COPCO COP 4050</b>						
	T51	605	52	8.9	T51*8D52-605	824-02119-60-101 824-02119-60-103 824-02119-60-202
<b>ATLAS COPCO COP 4050EX</b>						
	ST58	835	70	21.8	ST58*8D70-835	841-0253-83-101 841-0253-83-103 841-0253-83-202
	ST68	835	70	21.7	ST68*12D70-835	842-0253-83-101 842-0253-83-103 842-0253-83-202
<b>ATLAS COPCO COP 4050MUX</b>						
	ST58	835	90	26.8	ST58*8D90-835	841-0254-83-101 841-0254-83-103 841-0254-83-202
	ST68	835	90	26.9	ST68*8D90-835	842-0254-83-101 842-0254-83-103 842-0254-83-202
<b>ATLAS COPCO COP 2550UX</b>						
	ST58	770	77	17.5	ST58*8D77-770	841-02142-77-101 841-02142-77-103 841-02142-77-202
<b>ATLAS COPCO COP 3060MUX</b>						
	ST58	745	90	23.7	ST58*12D90-745	841-02143-74-101 841-02143-74-103 841-02143-74-202
	ST68	745	90	24.1	ST68*12D90-745	842-02143-74-101 842-02143-74-103 842-02143-74-202

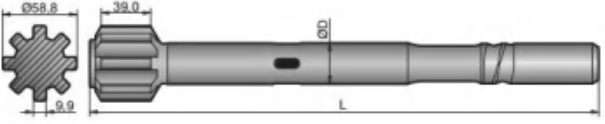
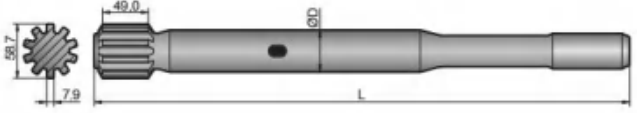
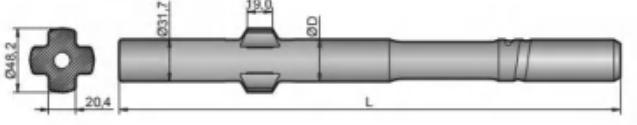
钎尾	螺纹	长度	直径	约重	产品型号	产品件号
		mm	mm	kg		
<b>SANDVIK HL300</b>						
	R32	400	32	2.6	R32*8D32-400	805-0101-40-101 805-0101-40-103 805-0101-40-202
	<b>SANDVIK HLX 5/HLX 5T</b>					
	R32	500	45	5.1	R32*10D45-500	805-0113-50-101 805-0113-50-103 805-0113-50-202
	T35	500	45	5.3	T35*10D45-500	821-0113-50-101 821-0113-50-103 821-0113-50-202
	T38	500	45	5.3	T38*10D45-500	822-0113-50-101 822-0113-50-103 822-0113-50-202
	R38	500	45	5.3	R38*10D45-500	807-0113-50-101 807-0113-50-103 807-0113-50-202
	R32	575	45	5.4	R32*10D45-575	805-0113-57-101 805-0113-57-103 805-0113-57-202
	T35	575	45	5.6	T35*10D45-575	821-0113-57-101 821-0113-57-103 821-0113-57-202
	T38	575	45	5.7	T38*10D45-575	822-0113-57-101 822-0113-57-103 822-0113-57-202
	T45	575	45	6.2	T45*10D45-575	823-0113-57-101 823-0113-57-103 823-0113-57-202
<b>SANDVIK L400, L500</b>						
	R32	380	32	2.0	R32*4D32-380	805-01121-38-101 805-01121-38-103 805-01121-38-202

钎尾	螺纹	长度	直径	约重	产品型号	产品件号
		mm	mm	kg		
<b>SANDVIK L600, L750</b>						
	T38	446	44	4.0	T38*4D44-446	822-01122-45-101 822-01122-45-103 822-01122-45-202
<b>SANDVIK 438LS, 438TS, HL538, HL538L, L550S</b>						
	R32	450	38	3.8	R32*4D38-450	805-01123-45-101 805-01123-45-103 805-01123-45-202
	R38	450	38	4.4	R38*4D38-450	807-01123-45-101 807-01123-45-103 807-01123-45-202
	T38	455	38	4.0	T38*4D38-455	822-01123-45-101 822-01123-45-103 822-01123-45-202
<b>SANDVIK 438, 538</b>						
	R32	430	38	3.0	R32*4D38-430	805-01124-43-101 805-01124-43-103 805-01124-43-202
<b>SANDVIK HL500</b>						
	R38	500	38	3.7	R38*8D38-500	807-01125-50-101 807-01125-50-103 807-01125-50-202
	T38	550	45	5.3	T38*8D45-550	822-01125-55-101 822-01125-55-103 822-01125-55-202
	T45	550	45	6.0	T45*8D45-550	823-01125-55-101 823-01125-55-103 823-01125-55-202

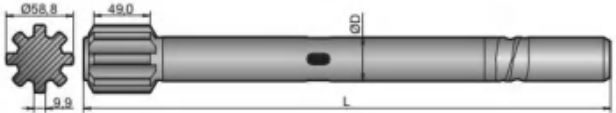
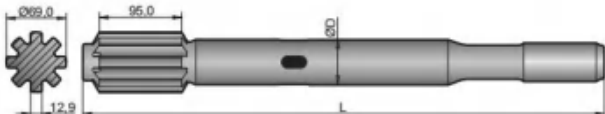
钎尾	螺纹	长度	直径	约重	产品型号	产品件号
		mm	mm	kg		
<b>SANDVIK HL500, HL500S</b>						
	R32	460	38	3.9	R32*8D38-460	805-01126-46-101 805-01126-46-103 805-01126-46-202
	R38	460	38	4.2	R38*8D38-460	807-01126-46-101 807-01126-46-103 807-01126-46-202
	T38	460	38	4.2	T38*8D38-460	822-01126-46-101 822-01126-46-103 822-01126-46-202
	R32	550	38	4.3	R32*8D38-550	805-01126-55-101 805-01126-55-103 805-01126-55-202
	T38	550	38	4.6	T38*8D38-550	822-01126-55-101 822-01126-55-103 822-01126-55-202
<b>SANDVIK HL700, HL800</b>						
	T45	600	45	7.2	T45*8D45-600	823-01127-60-101 823-01127-60-103 823-01127-60-202
	T38	600	52	8.0	T38*8D52-600	822-01127-60-101 822-01127-60-103 822-01127-60-202
	T45	600	52	8.5	T45*8D52-600	823-01127A-60-101 823-01127-60-103 823-01127-60-202
	T51	600	52	8.5	T51*8D52-600	824-01127-60-101 824-01127-60-103 824-01127-60-202

钎尾	螺纹	长度	直径	约重	产品型号	产品件号
		mm	mm	kg		
<b>SANDVIK HL600, HL600S</b>						
	T38	600	45	6.0	T38*8D45-600	822-01128-60-101 822-01128-60-103 822-01128-60-202
	T45	600	45	6.4	T45*8D45-600	823-01128-60-101 823-01128-60-103 823-01128-60-202
	T38	525	45	5.6	T38*8D45-525	822-01128-52-101 822-01128-52-103 822-01128-52-202
	T45	525	45	5.8	T45*8D45-525	823-01128-52-101 823-01128-52-103 823-01128-52-202
	T45	650	52	8.3	T45*8D52-650	823-01128-65-101 823-01128-65-103 823-01128-65-202
<b>SANDVIK HL645, HL645S</b>						
	T45	600	45	6.5	T45*8D45-600	823-01129-60-101 823-01129-60-103 823-01129-60-202
<b>SANDVIK HL 650-52, 700-52/PE-52/S-52, 710-52/S-52/PE-52/SPE-52, 800T-52/PE-52</b>						
	T38	600	52	8.4	T38*8D52-600	822-0120-60-101 822-0120-60-103 822-0120-60-202
	T45	600	52	8.5	T45*8D52-600	823-0120-60-101 823-0120-60-103 823-0120-60-202
	T51	600	52	8.6	T51*8D52-600	824-0120-60-101 824-0120-60-103 824-0120-60-202

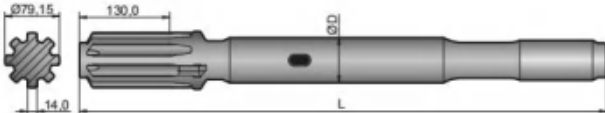
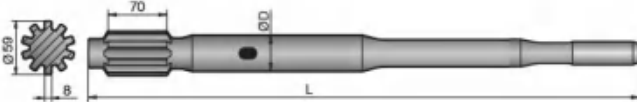
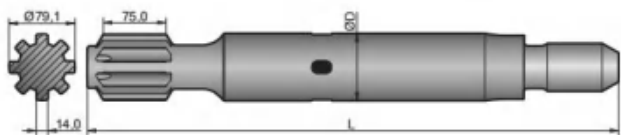
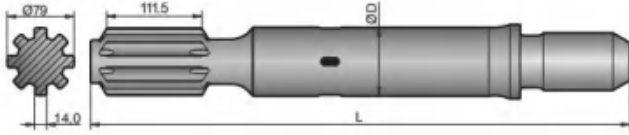
钎尾	螺纹	长度	直径	约重	产品型号	产品件号	
		mm	mm	kg			
<b>SANDVIK HL1000 PE-65, HL1500, HL1500PE-65, HL1560T-65</b>							
	T51	760	65	16.3	T51*8D65-760	824-01131-76-101 824-01131-76-103 824-01131-76-202	
	<b>SANDVIK RD520/RD525</b>						
		T38	525	45	5.6	T38*10D45-525	822-0186-52-101 822-0186-52-103 822-0186-52-202
T45		525	45	6.0	T45*10D45-525	823-0186-52-101 823-0186-52-103 823-0186-52-202	
T35		600	45	6.5	T35*10D45-600	821-0186-60-101 821-0186-60-103 821-0186-60-202	
T38		600	45	6.5	T38*10D45-600	822-0186-60-101 822-0186-60-103 822-0186-60-202	
T38		745	45	7.5	T38*10D45-745	822-0186-74-101 822-0186-74-103 822-0186-74-202	
<b>SANDVIK HL 1000</b>							
	ST58	635	80	18.4	ST58*8D80-635	841-01144-63-101 841-01144-63-103 841-01144-63-202	
	ST68	640	80	18.8	ST68*8D80-640	842-01144-64-101 842-01144-64-103 842-01144-64-202	
<b>SANDVIK HL 1500 S-80 Tube drilling</b>							
	ST58	635	80	17.0	ST58*8D80-635	841-0131-64-101 841-0131-64-103 841-0131-64-202	
	ST68	635	80	16.8	ST68*8D80-635	842-0131-64-101 842-0131-64-103 842-0131-64-202	



钎尾	螺纹	长度	直径	约重	产品型号	产品件号
		mm	mm	kg		
<b>FURUKAWA M 120 and PD 200</b>						
	T38	380	44	3.6	T38*4D44-380	822-0355-38-101 822-0355-38-103 822-0355-38-202
	T38	446	44	4.0	T38*4D44-446	822-0355-45-101 822-0355-45-103 822-0355-45-202
<b>FURUKAWA HD 609</b>						
	T38	690	45	6.3	T38*8D45-690	822-0358-69-101 822-0358-69-103 822-0358-69-202
	T45	620	45	6.4	T45*8D45-620	823-0358-62-101 823-0358-62-103 823-0358-62-202
<b>FURUKAWA HD 712</b>						
	T45	790	51	9.5	T45*8D51-790	823-0361-79-101 823-0361-79-103 823-0361-79-202
	T51	790	51		T51*8D51-790	824-0361-79-101 824-0361-79-103 824-0361-79-202
<b>FURUKAWA HD 90</b>						
	R38	515	40	4.3	R38*6D40-515	807-03132-51-101 807-03132-51-103 807-03132-51-202
<b>FURUKAWA HD 190</b>						
	R38	500	40	4.5	R38*8D40-500	807-03133-50-101 807-03133-50-103 807-03133-50-202
	T38	500	40	4.5	T38*8D40-500	822-03133-50-101 822-03133-50-103 822-03133-50-202

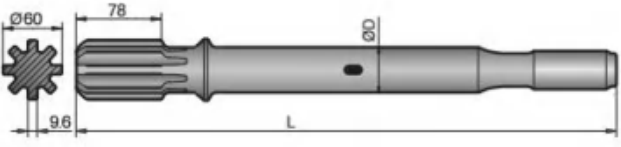
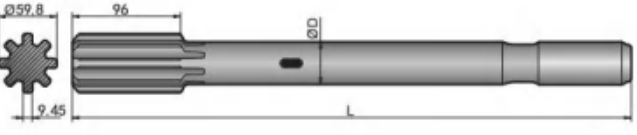
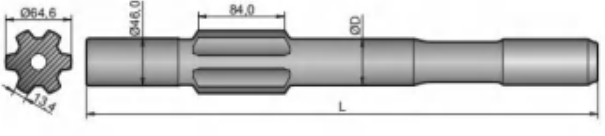
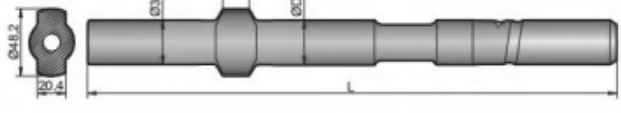

钎尾	螺纹	长度	直径	约重	产品型号	产品件号
		mm	mm	kg		
<b>MONTABERT HC80, HC90, HC105, HC120</b>						
	R32	440	38	3.6	R32*8D38-440	805-05137-44-101 805-05137-44-103 805-05137-44-202
	R38	440	38	3.9	R38*8D38-440	807-05137-44-101 807-05137-44-103 807-05137-44-202
	T38	440	38	3.9	T38*8D38-440	822-05137-44-101 822-05137-44-103 822-05137-44-202
	T38	500	38	4.2	T38*8D38-500	822-05137-50-101 822-05137-50-103 822-05137-50-202
<b>MONTABERT HC80RP, HC105RP, HC107RP, HC108RP, HC109RP</b>						
	T38	770	45	8.4	T38*8D45-770	822-05147-77-101 822-05147-77-103 822-05147-77-202
	T45	770	45	8.6	T45*8D45-770	823-05147-77-101 823-05147-77-103 823-05147-77-202
	T38	670	45	7.2	T38*8D45-670	822-05147-67-101 822-05147-67-103 822-05147-67-202
	T45	670	45	7.5	T45*8D45-670	823-05147-67-101 823-05147-67-103 823-05147-67-202
<b>MONTABERT HC120RP, HC150RP, HC155RP, HC158RP</b>						
	T45	670	51	8.8	T45*8D51-670	823-05148-67-101 823-05148-67-103 823-05148-67-202
	T51	670	51	8.9	T51*8D51-670	824-05148-67-101 824-05148-67-103 824-05148-67-202
	T51	770	51	10.3	T51*8D51-770	824-05138-77-101 824-05138-77-103 824-05138-77-202

钎尾	螺纹	长度	直径	约重	产品型号	产品件号
		mm	mm	kg		
<b>MONTABERT HC 95</b>						
	T38	512	45		T38*8D45-512	822-0585-51-101 822-0585-51-103 822-0585-51-202
<b>MONTABERT HC 110</b>						
	T38	420	45	4.7	T38*8D45-420	822-0585-42-101 822-0585-42-103 822-0585-42-202
<b>INGERSOLL-RAND YH65, YH70</b>						
	T38	500	45	5.2	T38*6D45-500	822-04139-50-101 822-04139-50-103 822-04139-50-202
	T45	500	45	5.5	T45*6D45-500	823-04139-50-101 823-04139-50-103 823-04139-50-202
<b>INGERSOLL-RAND 350</b>						
	R32	380	32	2.1	R32*2D32-380	805-04146-38-101 805-04146-38-103 805-04146-38-202

钎尾	螺纹	长度	直径	约重	产品型号	产品件号
		mm	mm	kg		
<b>INGERSOLL-RAND VL120, VL140</b>						
	R32	381	44	3.4	R32*4D44-381	805-04140-38-101 805-04140-38-103 805-04140-38-202
	R38	381	44	3.6	R38*4D44-381	807-04140-38-101 807-04140-38-103 807-04140-38-202
	T38	381	44	3.7	T38*4D44-381	822-04140-38-101 822-04140-38-103 822-04140-38-202
	T45	381	44	3.9	T45*4D44-381	823-04140-38-101 823-04140-38-103 823-04140-38-202
<b>INGERSOLL-RAND YH65RP</b>						
	T38	700	45	7.8	T38*6D45-700	822-04141-70-101 822-04141-70-103 822-04141-70-202
	T45	700	45	7.9	T45*6D45-700	823-04141-70-101 823-04141-70-103 823-04141-70-202
<b>INGERSOLL-RAND YH80A</b>						
	T38	500	51	5.5	T38*6D51-500	822-0465-50-101 822-0465-50-103 822-0465-50-202
	T45	500	51	5.7	T45*6D51-500	823-0465-50-101 823-0465-50-103 823-0465-50-202
	T51	500	51	6.4	T51*6D51-500	824-0465-50-101 824-0465-50-103 824-0465-50-202



**力之于天地**

**掘之于無疆**

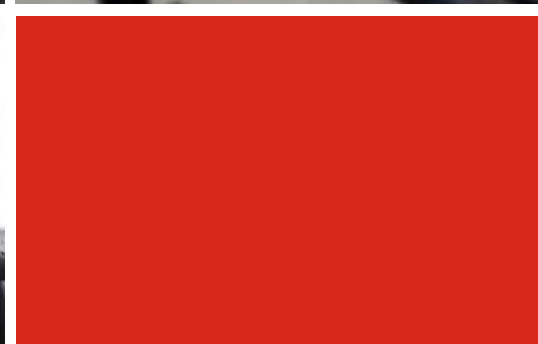
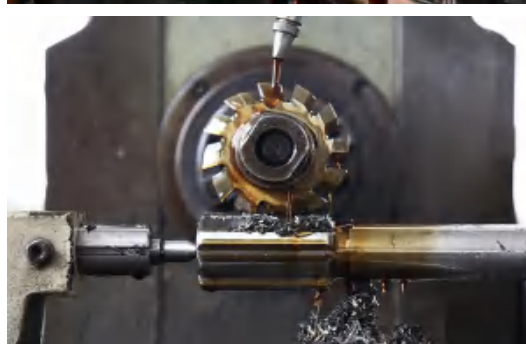
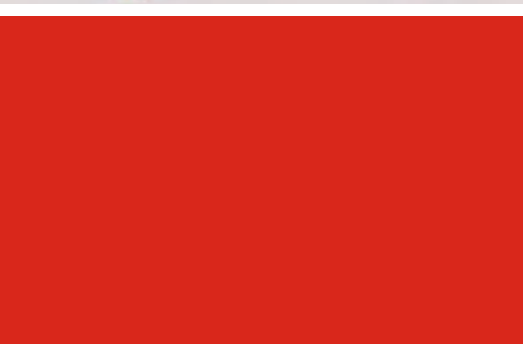

## 葫芦岛力天重工机械有限公司

Litian Heavy Industry Machinery Co.,Ltd

地址：辽宁省葫芦岛市打渔山泵业产业园区同心路 6 号

网址：[www.china.litechtools.com](http://www.china.litechtools.com)

邮箱：[litian@litechtools.com](mailto:litian@litechtools.com)

电话：+86 18080496772

座机：+86 0429-2269666

